

MODEL MB-372
1-THREAD, CHAINSTITCH BUTTON ATTACHING MACHINE

MODEL MB-373
1-THREAD, CHAINSTITCH BUTTON ATTACHING MACHINE WITH AUTOMATIC THREAD TRIMMER

INSTRUCTION BOOK

Before operating your JUKI Chainstitch Machine, please read this Instruction Book carefully in order to operate it in the correct and efficient manners.

CAUTION BEFORE OPERATION

1. Before applying power, release the stop-motion mechanism and turn by hand the needle driving pulley in order to ensure that the machine is in order.
2. Operate the machine at a speed of 1,200 to 1,300 s.p.m. for the first one month.
3. Make sure that the machine rotates backwards when viewed from the operator's side. Don't let it rotate in the reverse direction.

CAUTIONS IN OPERATION

1. Don't put your hand under the needle when you turn the main switch "on" or operate the machine.
2. Don't put your fingers into the thread take-up cover.
3. Don't forget to turn the main switch "off" before you tilt the machine head back or remove the V-belt.
4. Never bring your fingers or hair close to, or place anything on the handwheel, V-belt, bobbin winder wheel or motor during operation. It may lead to serious personal injuries.
5. If your machine is provided with a belt cover, finger guard and eye guard, never operate your machine with any of them removed.

1. INSTALLATION OF MACHINE HEAD

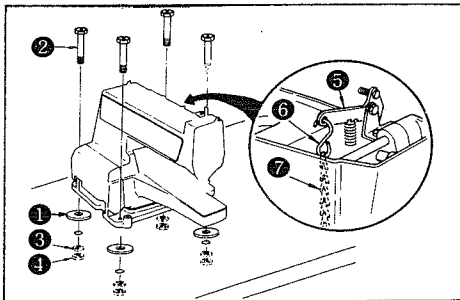

Put rubber cushion ① on the table, place the machine head on the rubber cushion and fix it to the table using screws ②, plain washers ③ and nuts ④. Attach "S" chain hook ⑥ and chain ⑦ to stopmotion trip lever ⑤.

2. LUBRICATION

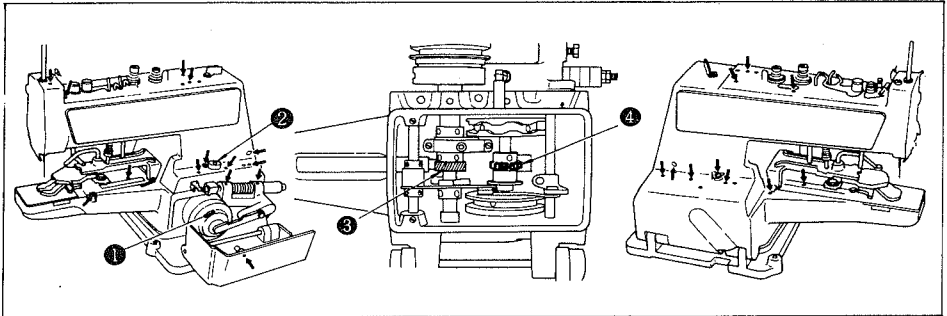

1. Apply JUKI New Defrix Oil No. 1 to the components shown by the arrows.
2. Open the stop-motion and pulley cover (right), remove screw ① from the needle driving pulley and apply some grease.
3. Loosen connecting screws ②, tilt the head backward and apply some grease to driving worm gear ④ and gear ③.
4. Ensure that the oil felt on the machine sub-base is saturated with the lubricating oil. If the oil is not enough, add some oil.

3. ATTACHING THE NEEDLE

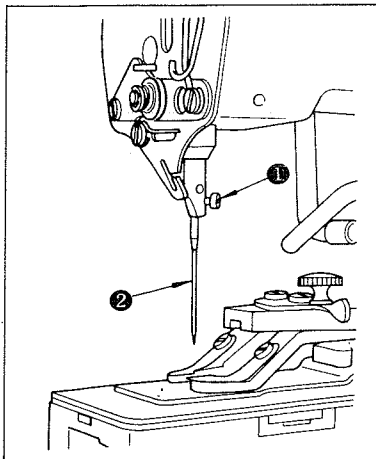

- ★ Cut power off for safety.
 - ★ Use a standard needle of TQx7 #16 for MB-372 and TQx7 #20 for MB-373.
1. Loosen screw ①.
 2. Insert needle ② into the needle bar facing its long groove towards you as far as it will go.
 3. Tighten screw ① firmly.

4. ATTACHING THE NEEDLE BAR GUARD

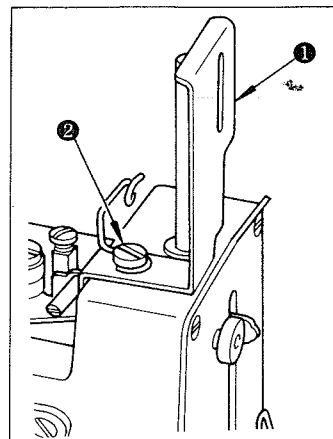

1. Loosen screw ② and remove the thread guide No. 2.
 2. Place needle bar guard ① under the thread guide No. 2.
 3. Fix the thread guide No. 2 and needle bar guide ① together using screw ②.
- (Notes) If your machine has a wiper magnet, attach the needle bar guard on to the wiper magnet base.

5. ATTACHING THE BUTTON TRAY ASSEMBLY

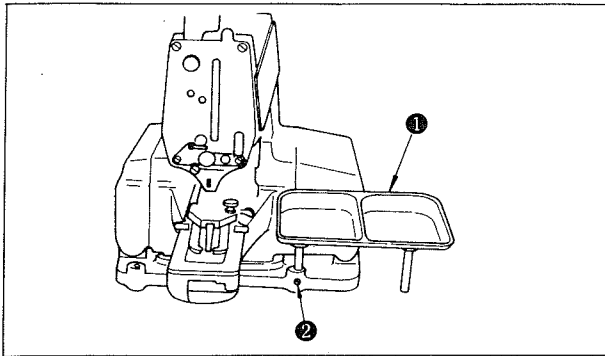

Insert the posts of button tray **1** in hole on the right of the machine sub-base and tighten each setscrew **2**. You may use also the installation hole on the left if the operator wants.

7. THREAD TENSION ADJUSTMENT

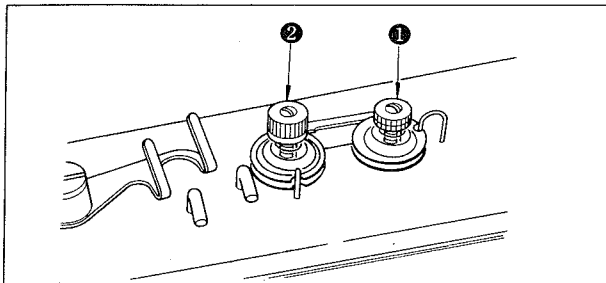

Tension post No. 1 **1** is used to adjust the thread tension to sew on the button and a relatively low tension will be enough. Tension post No. 2 **2** is used to adjust the thread tension applied to the root of the button sewing stitches. This tension must be determined according to the type of thread, fabric and thickness of the button and must be higher than that of tension post No. 1 **1**. Turn the tension nuts clockwise to increase or counterclockwise to reduce the thread tension. Turn the adjusting nut clockwise to increase or counterclockwise to reduce the tension.

6. THREADING THE MACHINE

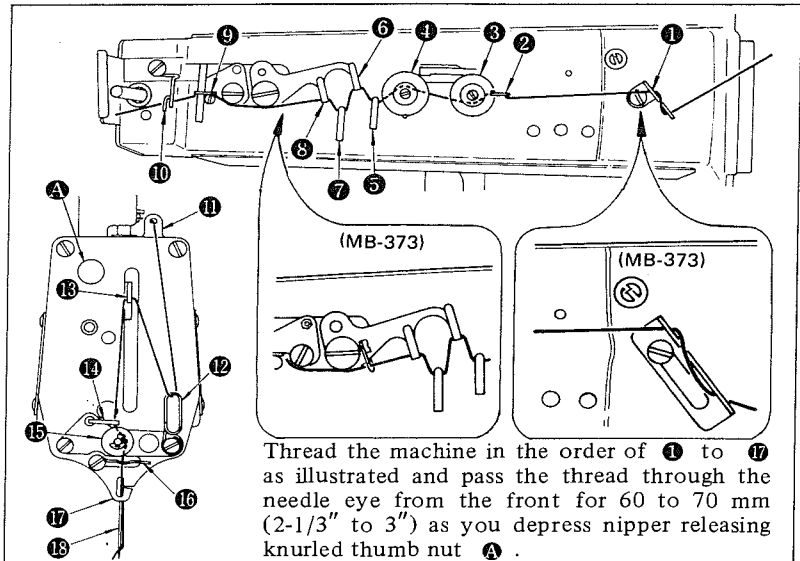

Thread the machine in the order of **1** to **17** as illustrated and pass the thread through the needle eye from the front for 60 to 70 mm (2-1/3" to 3") as you depress nipper releasing knurled thumb nut **A**.

8. ADJUSTMENT OF THE THREAD PULL-OFF LEVER

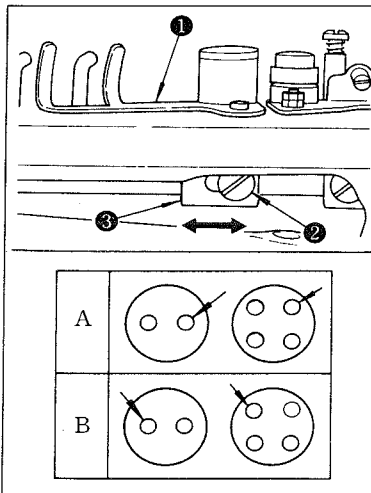

Adjustment of the thread pull-off lever **1**, insert a screw driver through an opening in the machine arm side cover (left), loosen screw **2** and adjust the position of nipper bar block (rear) **3** to the left or the right.

If the end of thread is drawn from arrow hole A in the button after sewing, change the position of nipper bar block (rear) **3** to the left. Move the lever to the right when the thread end comes out from arrow hole B.

9. NEEDLE-TO-LOOPER RELATION

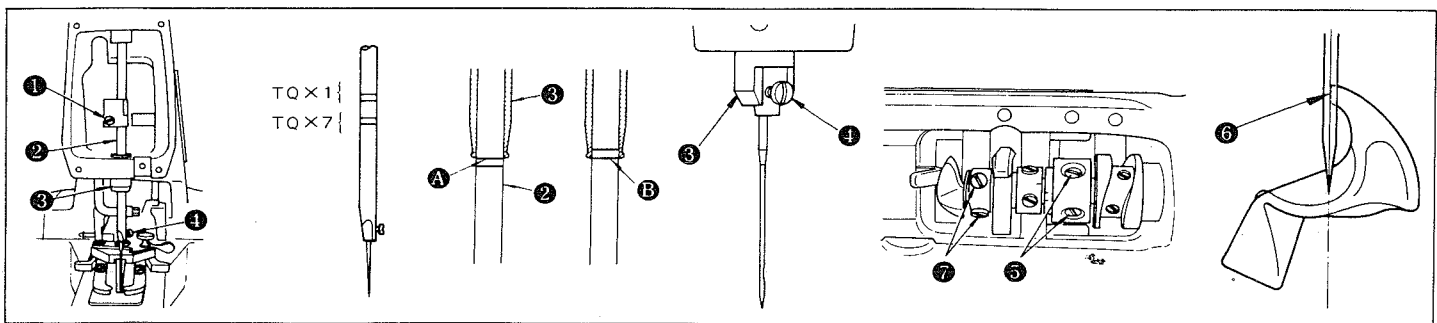

★ Adjust the needle-to-looper relation as follows;

1. Depress the pedal fully forward, turn the needle driving pulley in the normal sewing direction to bring down the needle bar to the lowest point of its stroke and loosen screw **1**.

(Adjusting the needle bar height)

2. Adjust the height of the needle bar using top two lines engraved on the needle bar for the TQx1 needle and using the bottom two lines for the TQx7 needle. Align the upper line **A** with the bottom end face of needle bar bushing (lower) **3** and tighten screw **1** in the way that needle clamp screw **4** rests in the slot of the needle bar bushing (lower) **3**.

(Looper position)

3. Loosen screws **5** and turn by hand the needle driving pulley until lower line **B** of two lines aligns with the bottom end face of needle bar bushing (lower) **3**.
4. By keeping the machine in this state, align looper blade **6** with the center of the needle and tighten screws **5**.
5. Loosen screw **7** and provide a 0.05 to 0.1 mm clearance between the looper and the needle. Tighten screw **7**.

10. ADJUSTMENT OF THE NIPPER

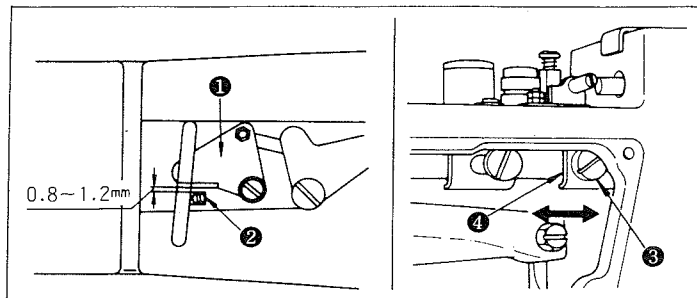

Provide a 0.8 to 1.2 mm ($1/32''$ to $3/64''$) clearance between nipper ① and nipper block ② to prevent the nipper from nipping the thread while stitching. Loosen screw ③ and move nipper bar block ④ to the left or the right.

11. POSITION OF THE NEEDLE GUIDE

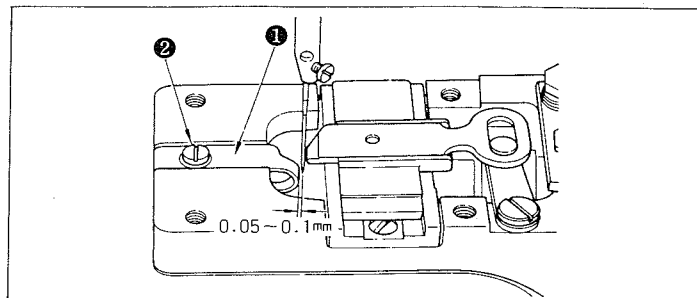

Loosen screw ② and provide a 0.05 to 0.1 mm clearance between the needle guide ① and the needle by moving the needle guide ① to the left or the right when the needle is in the lowest position.

12. HEIGHT OF THE BUTTON CLAMP

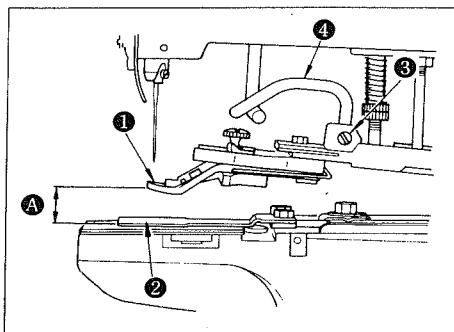

The standard clearance A between the bottom face of button clamp jaw lever ① and the top face of feed plate ② is 12 mm ($15/32''$) for MB-372 and 9 mm ($25/64''$) for MB-373. Loosen screw ③ and adjust the height of button clamp lifting hook ④.

13. WORK PRESSING FORCE

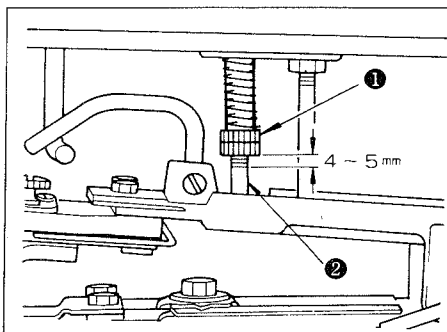

The standard work pressing force is obtained by providing a 4 to 5 mm ($5/32''$ to $13/64''$) clearance between the bottom face of nut ① and the bottom end of the screw of pressure adjusting bar ②.

14. ADJUSTMENT OF THE BUTTON CLAMP STOP LEVER

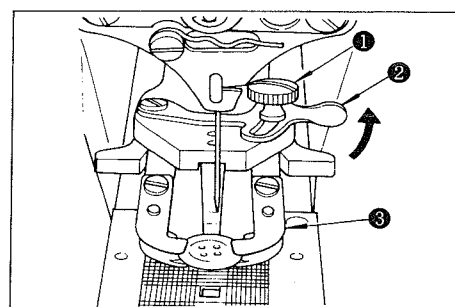

Set the machine for stop-motion state, loosen clamp screw ①, place a button correctly in the sewing position and adjust button clamp stop lever ② to permit the button properly to rest on button clamp jaw levers ③. Tighten clamp screw ① after determining the distance between the left and right jaw levers ③.

15. TIMING OF THREAD TENSION RELEASE

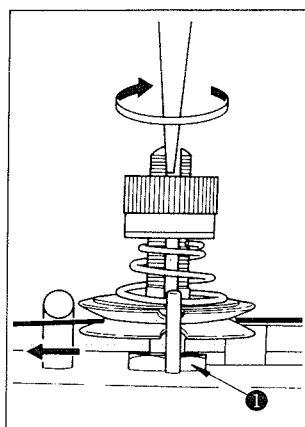

Turn the needle driving pulley as you draw the thread in the direction of the arrow as illustrated, and you will find a point at which the tension disc on the tension post No. 2 release the thread. At this moment, the standard distance from the top end of the needle bar down to the top end of the needle bar bushing (upper) is 54 to 56 mm ($2-1/8''$ to $2-13/64''$). Relation of the needle bar height (above-mentioned distance; 54 to 56 mm) to the timing of thread tension release is adjustable by turning the tension post No. 2; loosen nut ①, insert the blade of a screw driver to the top slot of the tension post No.

2 and turn it in the direction of the arrow to lower the needle bar, (to reduce the said distance), and vice versa.

Your adjustment is required when the following troubles are frequency;

1. When the stitch made on the wrong side of the workpiece is too loose; ---Make the needle bar slightly higher.
2. When the thread is broken at the time of stop-motion; ---Make the needle bar slightly higher.
3. When the thread is broken frequently; ---Make the needle bar slightly lower.

16. SETTING FOR 2-OR 4-HOLE BUTTONS

Measure the distance between two holes in a button and set equally crosswise and lengthwise feed regulators for 4-hole buttons.

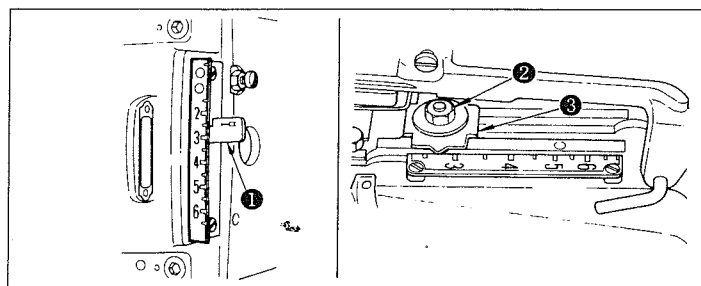

★ Lengthwise feed

Push down lengthwise feed adjusting lever ① and set it to "0" for 2-hole buttons or a corresponding amount for 4-hole buttons.

★ Crosswise feed

Crosswise nut ② and set pointer ③ to a corresponding amount indicated by the crosswise feed graduation plate. Tighten firmly nut ②.

(Caution) Before operating the machine, ensure that the needle enters the center of each hole in the button.

17. SETTING A NUMBER OF STITCHES

A number of stitches to sew a button is set by stitch adjusting cam knob ①, stitch selecting lever (small) ④, adjusting screw ⑤ and clamp screw ③ which are accessible by opening the left-hand cover (stop-motion & pulley cover). You can easily adjust these components without removal of the speed-slowng mechanism.

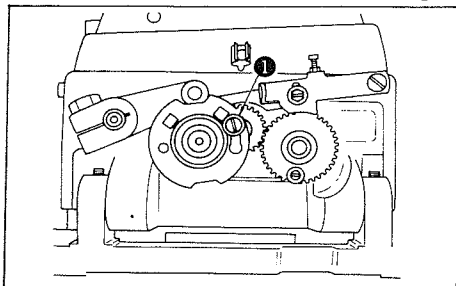

★ 8 stitches (6 stitches)

Pull stitch adjusting cam knob ① and set it as shown in the illustration.

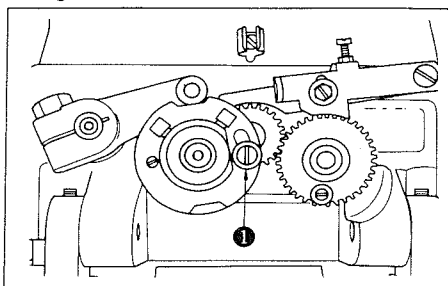

★ 16 stitches (12 stitches)

When stitch cam knob ① being set for "8 stitches" has arrived at the right end as illustrated, set knob ① in the illustrated position.

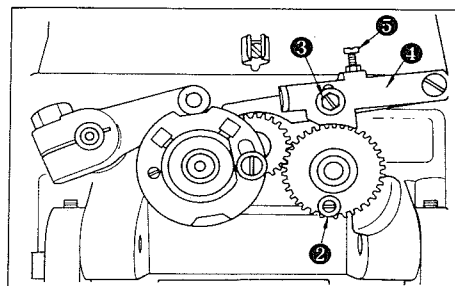

★ 32 stitches (24 stitches)

When stitch adjusting roller ② arrived at the lowest point of its trajectory with the 16-stitch setting, loosen clamp screw ③, push down stitch selecting lever (small) ④ with your fingers and retighten screw ③. If the machine does not make 32 stitches, loosen clamp screw ③ and turn adjusting screw ⑤ until 32 stitches are made.

18. AUTOMATIC THREAD TRIMMER (EXCLUSIVE FOR MB-373)

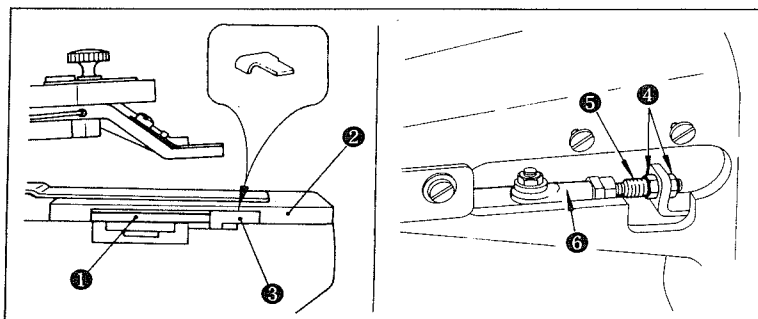

★ Position of the moving knife

When the machine stops in the state of "stop-motion" and its button clamp assembly rests in the highest position, there must be a standard clearance of 13 mm (33/64") between thread trimming connecting link (front) ① and the end face of the slit in throat plate ②. This clearance is determined gauge ③ which is stored in the accessory box; tilt the head backwards, remove the bed oil shield, loosen two nuts ④ and adjust the clearance by moving connecting screw ⑤ in the axial direction. When you tighten two nuts ④, ensure that joint ⑥ stays in the horizontal position.

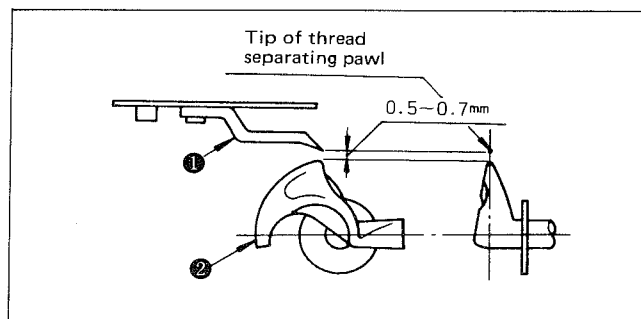

★ Height of the moving knife thread separation nail

There must be a 0.5 to 0.7 mm (1/64" to 1/32") clearance between looper blade point ② and thread separation nail ①. If nail ① does not provide the necessary clearance, bend the nail slightly and adjust the clearance.

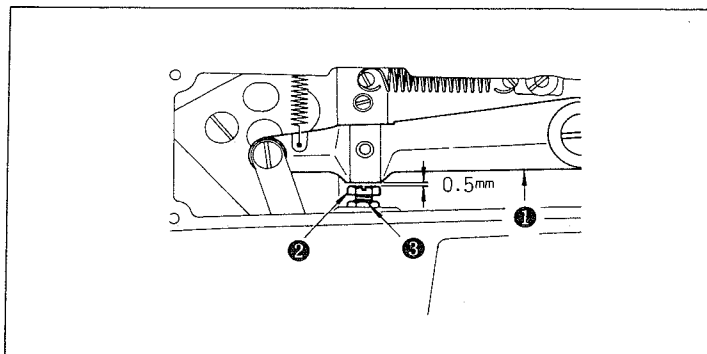

★ Clearance between the button clamp lifting lever and the adjusting screw

Provide a 0.5 mm (1/64") clearance between button clamp lifting lever ① and adjusting screw ② and then tighten nut ③.

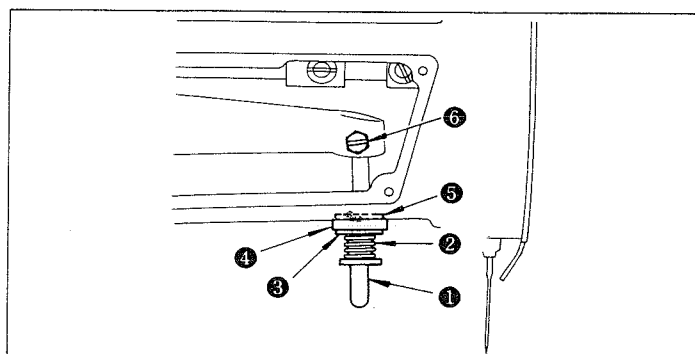



★ How to set the button clamp lifting rod

Put moving knife spring ②, stop-motion rubber cushion ④ and stop-motion rubber cushion washer ⑤, in this order, to button clamp lifting rod ①. After making sure that the stop-motion mechanism has engaged completely, fix the button clamp lifting rod by tightening screw ⑥ in the way that the end face of the stop-motion rubber cushion washer comes into close contact with the jaw of the machine arm.

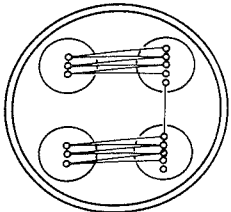
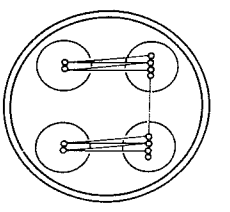
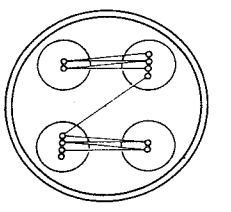
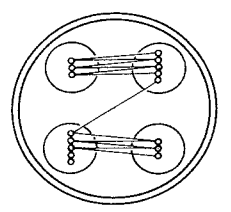
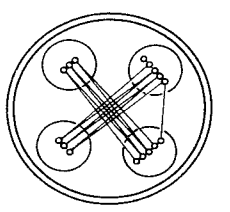
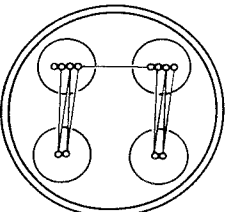
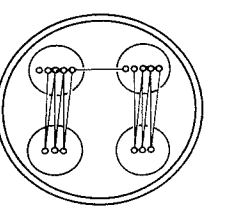
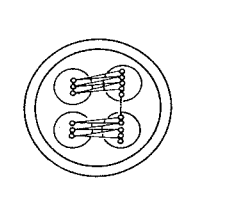
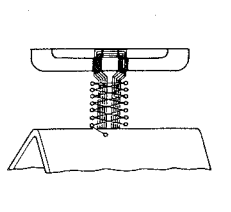
19. SUBCLASS MODELS

MB-372 MB-373	MB-372-4 MB-373-4	MB-372-5 MB-373-5	MB-372-10 MB-373-10	MB-372-11 MB-373-11
8, 16, 32 stitches	6, 12, 24 stitches	6, 12, 24 stitches	8, 16, 32 stitches	8, 16, 32 stitches
				
MB-372-6 MB-373-6	MB-372-12 MB-373-12	MB-372-16/Z010-B MB-373-15/Z046	MB-372-15/Z016	
6, 12, 24 stitches	8, 16, 32 stitches	8, 16, 32 stitches	16, 32 stitches	
				

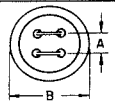
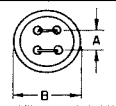
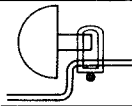
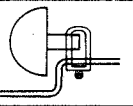
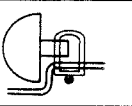
20. ATTACHMENTS

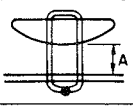
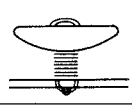
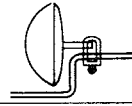
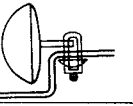
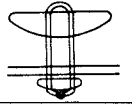
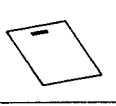
Use	Flat buttons		Shank buttons			Snaps
	Large-size	Medium-size	General	Special	Luis type	
MB-372	Z001	Z002	Z003	Z006	Z010	Z007
MB-373	Z031	Z032	Z033	Z036	Z040	Z037
						
Remarks	Button size: A: 3~6.5mm (1/8"~1/4") B: φ20~28mm (25/32"~1-9/64")	Button size: A: 3~5mm (1/8"~13/64") B: φ12~20mm (15/32"~25/32")	Button diameter: Less than 16mm (5/8") Shank size: Thickness 6~5mm (15/64"~ 13/64") Width: 3~ 2.5mm (1/8"~3/32")	Special attachment for buttons having shank	Button size: Same as Z003 (Z033), but possible to sew buttons hav- ing some variations of shank in shape.	Snap size: A: 8mm (5/16")
Use	Wrapped-around buttons		Metal buttons		Use	Labels
	First process	Second process	General	Stay button sewing		
MB-372	Z004	Z005	Z008	Z012	Z009	Z014
MB-373	Z004	Z035	Z038	Z042	Z039	Z044
						
Remarks	Thread shank height: A: 5.5mm (7/32")			Common to Z008 (Z038)	Common to Z004	Crosswise feed: 3~6.5mm (1/8"~1/4")

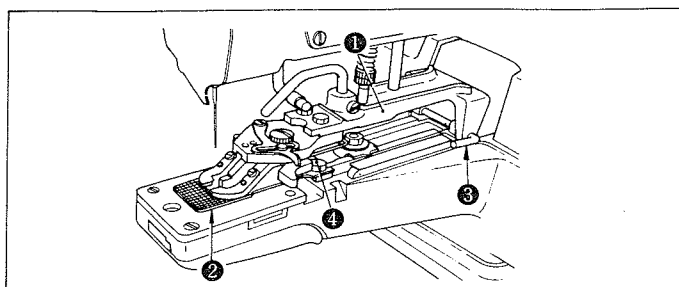

In order to install the attachment on the machine, you may have to remove the button clamp mechanism or feed plate. Dislocate a snap ring from button clamp installing stud ③, and you will be able to remove button clamp mechanism assembly ①. Loosen setscrews ④, and you can remove feed plate ②.

★ Attachment for shank buttons (Pearl buttons) (Z003, Z006, Z010, Z033, Z036, Z040)

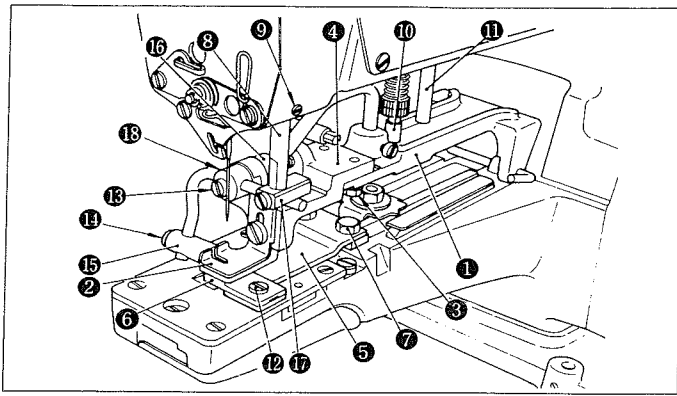

(INSTALLATION)

Remove both the button clamp mechanism assembly and the feed plate from the machine and install attachment ① in place. Loosen screws ③ and adjust button clamp bracket ④ to permit the needle to come down in the middle of the needle slot in shank button adaptor ②. Attach button clamp feed plate ⑤ using screws ⑦ in the way that it permits the needle to come down in the middle of the needle slot in work support plate ⑥. Insert the top end of button clamp stud ⑧ into an opening in the jaw of the machine arm and fasten it by screw ⑨.

(When attaching Z010 or Z040, you must change also button clamp pressure adjusting bar ⑩ and button clamp stopper pin ⑪ at the same time.)

(ADJUSTMENT AND OPERATION)

1. Loosen screw ⑫, let work support plate ⑥ recedes 0.5 to 1.0 mm (1/64" to 3/64") from the left end of button clamp jaw lever ② and retighten screw ⑫.
 2. Set a button in place, loosen screws ⑬ and ⑭ and align shank button holding clamp ⑮ with the center of the button.
 3. Shank button holding clamp ⑮ must give proper pressure to the button so that the button stays steadily in position while being sewn. Loosen a setscrew in thrust collar ⑯ and rotate the thrust collar until shank button holding clamp ⑮ provides proper pressure.
 4. You may fix button clamp block ⑰ in a convenient position for operation.
- (Caution) When you fix the thrust collar, ensure that button clamp rotating shaft ⑩ does not play axially in its bracket.

★ Attachment for the first process of wrapped-around buttons (Z004)

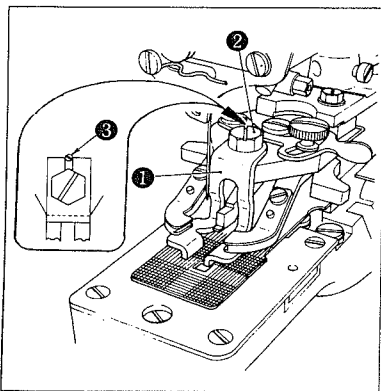

(INSTALLATION)

Attach wrapped-around button foot ① to the ordinary button clamp jaw levers using screw ② and guide pin screw ③. Align foot ① with the jaw levers so that they permit a button to rest in the middle.

(ADJUSTMENT AND OPERATION)

Adjustment and operation is almost same as those for the flat buttons, but you must adjust the thread pull-off lever to provide more amount of thread in order to make the thread loose below the button for thread shank formation. (See 8. Adjustment of the thread pull-off lever).

★ Attachment for the second process of wrapped-around buttons (Z005, Z035)

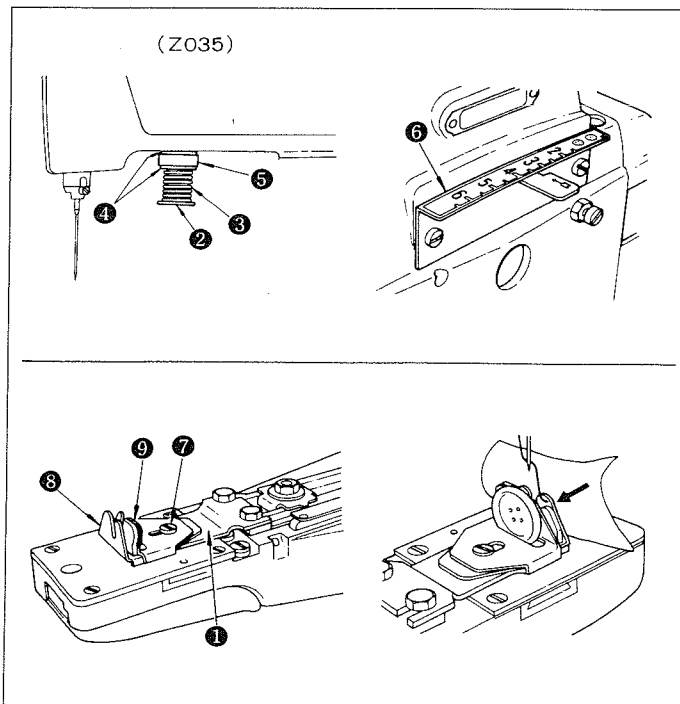

(INSTALLATION)

Remove the button clamp mechanism assembly, button clamp pressure adjusting bar and feed plate from the machine and install attachment for the second process of wrapped-around buttons ①. When you install a Z035 attachment, you must remove also the button clamp lifting rod. Insert moving knife push-back spring ③, washer ④, cushion ⑤ and washer ④ in spring guide shaft ② in this order. Make certain that the stop-motion mechanism has completely engaged, and install the attachment assembly in place in the way that cushion ⑤ comes into close contact with the surface of the machine arm without play. Then, replace lengthwise feed graduated plate ⑥.

(ADJUSTMENT AND OPERATION)

1. Loosen screw ⑦ and adjust the thread shank length by moving guide (large) ⑧ and guide (small) ⑨ in line with the point of needle entry.
2. Set a button (tilt it slightly for easy insertion) and pass the thread as the arrow shows.
3. Set the lengthwise feed "0".
When you sew 16 stitches with Z035, set it "1.5mm" instead of "0".

★ Attachment for snaps (Z007, Z037)

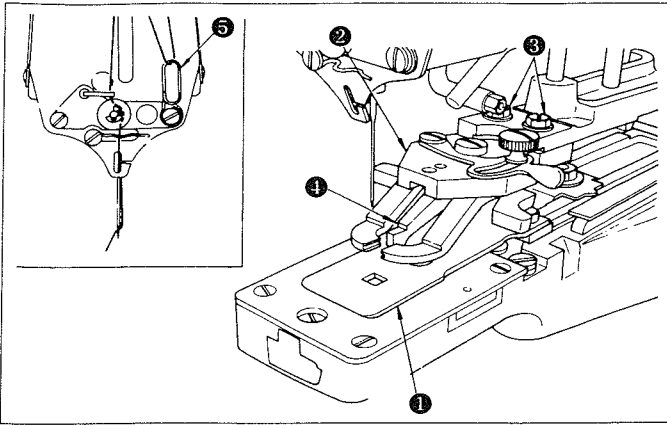

(INSTALLATION)

Remove the button clamp mechanism assembly and the feed plate. Set both the crosswise feed and lengthwise feed graduated plate to "4 mm". Install snap clamp feed plate ① in the way that the needle drops evenly at four corners of its square opening. Install snap attachment assembly ② on the machine, place a snap on the snap clamp jaw levers and make sure that the needle drops accurately in each hole in the snap. If necessary, loosen hex head screws ③ and adjust the position accurately.

Lastly, make sure that the concave section on the bottom face of snap clamp slide guide ④ accurately matches the convex section on snap clamp feed plate ①. Replace thread guide No. 3 ⑤.

★ Attachment for metal buttons (Z008, Z012, Z038, Z042)

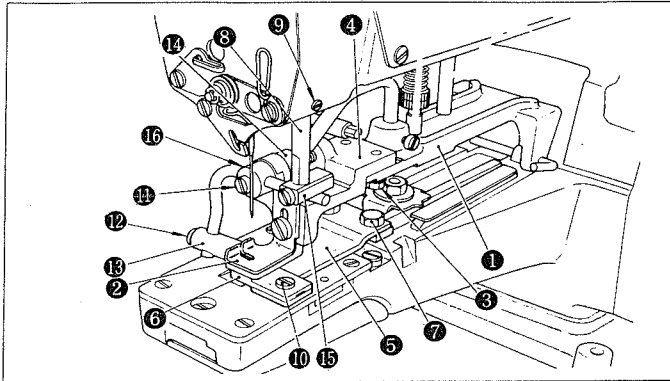

(INSTALLATION)

Remove both the button clamp mechanism assembly and the feed plate from the machine and install attachment ① in place. Loosen screws ③ and adjust button clamp bracket ④ to permit the needle to come down in the middle of the needle slot in metal button adaptor ②. Attach button clamp feed plate ⑤ using screws ⑦ in the way that it permits the needle to come down in the middle of the needle slot in work support plate ⑥. Insert the top end of button clamp stud ⑧ into an opening in the jaw of the machine arm and fasten it by screw ⑨.

(ADJUSTMENT AND OPERATION)

1. Loosen screw ⑩, let work support plate ⑥ recedes 1.0 to 1.5 mm (3/64" to 1/16") from the left end of button clamp jaw lever ② and retighten screw ⑩.
2. Set a button in place, loosen screws ⑪ and ⑫ and align metal button holding clamp ⑬ with the center of the button.

3. Metal button holding clamp ⑬ must give proper pressure to the button so that the button stays steadily in position while being sewn. Loosen a setscrew in thrust collar ⑭ and rotate the thrust collar until metal button holding clamp ⑬ provides proper pressure.

4. You may fix button clamp block ⑮ in a convenient position for operation.

(Caution) When you fix the thrust collar, ensure that button clamp rotating shaft ⑯ does not play axially in its bracket.

21. SPECIFICATIONS

	MB-372	MB-373
Sewing speed	Max. 1,500 s.p.m.	
Number of stitches	8, 16 and 32 stitches (6, 12 and 24 by changing the cam)	
Amount of feed	Crosswise feed: 2.5 ~ 6.5 mm (3/32" ~ 1/4") Lengthwise feed: 0 ~ 6.5 mm (0 ~ 1/4")	
Button size	10 ~ 28 mm (25/64" ~ 1-7/64") in diameter	
Needle	TQ x 7, TQ x 1 #16 (#18, #20)	TQ x 7, TQ x 1, #20 (#18)
Lubricating oil	JUKI New Defrix Oil No. 1	

22. MOTOR PULLEY AND BELT

(1) For this machine a single-phase or 3-phase 200 watts (1/4 HP) universal motor is used.

(2) A round leather belt (φ7 × 650 mm) is used.

(3) The sewing speed depends on the diameter of the motor pulley as listed below;

Frequency	Sewing speed	Motor pulley Part No.	Motor pulley Outer diameter
50Hz	1,500 s.p.m.	B7101372000	71 mm
	1,250	B7102372000	59.2
60Hz	1,500	B7102372000	59.2
	1,300	B7103372000	51.3

★ The effective diameter of motor pulley is obtained by subtracting 1 mm (3/64") from its outer diameter.

★ The motor must revolve in the counterclockwise direction when viewed from the motor pulley side. Take care not to let it run in the reverse direction.

23. TROUBLES AND CORRECTIVE MEASURES

TROUBLES	CAUSES	CORRECTIVE MEASURES
1. Thread breakage.	<ol style="list-style-type: none"> (1) The yoke slide does not move in the correct way. (2) The thread tension post No. 2 fails to release the thread at correct timing. (3) The thread nipper catches the thread. (4) The needle does not enter the center of the holes in the button. (5) The needle is too thick for the diameter of the hole in the button. 	<ul style="list-style-type: none"> ○ Adjust the timing of the motion of the yoke slide at each end. ○ Make the thread release timing slightly earlier. ○ Adjust the position of the nipper bar block. ○ Adjust the button clamp jaw lever holder. ○ Replace the needle by a thinner one.
2. Buttons are not sewn tightly.	<ol style="list-style-type: none"> (1) The yoke slide does not move in the correct way. (2) The thread tension post No. 2 fails to release the thread at correct timing. (3) The thread tension post No. 2 does not give sufficient tension. (4) The needle does not enter the center of the holes in the button. (5) The work pressing force is too high or too low. 	<ul style="list-style-type: none"> ○ Adjust the timing of the motion of the yoke slide at each end. ○ Make the thread release timing slightly later. ○ Tighten the tension nut of tension post No. 2. ○ Adjust the button clamp jaw lever holder. ○ Adjust the work pressing force properly.
3. The first stitch trails relatively long thread from the right side of the button.	The thread pull-off lever does not work properly.	<ul style="list-style-type: none"> ○ Adjust the thread pull-off lever by the nipper bar block (rear).
4. Thread trimming failure in the state of stop-motion.	<ol style="list-style-type: none"> (1) The thread tension post No. 2 fails to release the thread at correct timing. (2) The needle hits the edge of the holes in the button. (3) The button clamp assembly does not rise to the necessary height. (4) The thread nipper fails to press the thread. (5) The work pressing force is too high. 	<ul style="list-style-type: none"> ○ Make the thread release timing slightly later to give more tension to the stitches. ○ Adjust the button clamp jaw lever holder. ○ Provide a 12 mm (15/32") clearance between the feed plate and the button clamp jaw levers when risen. ○ Adjust the nipper bar block. ○ Adjust the work pressing force by the pressure adjusting nut.

ONLY FOR MB-373

TROUBLES	CAUSES	CORRECTIVE MEASURES
1. Thread trimming failure.	<ol style="list-style-type: none"> (1) The moving knife does not separate the thread on the fabric with its separation nail. (2) The needle does not enter the center of the holes in the button. (3) The last stitch skips. (4) The moving knife separation nail is too high or too low. 	<ul style="list-style-type: none"> ○ Adjust the position of the moving knife. ○ Adjust the button clamp jaw lever holders. ○ Adjust the looper. ○ Adjust the height of the moving knife thread separation nail.
2. The needle thread is cut in two places on the wrong side of the fabric.	<ol style="list-style-type: none"> (1) The moving knife is set in wrong place. (2) The moving knife thread separation nail is too high or too low. 	<ul style="list-style-type: none"> ○ Adjust the position of the moving knife when the machine is in the stop-motion state. ○ Adjust the height of the thread separation nail.
3. Buttons trials too long thread after thread trimming.	<ol style="list-style-type: none"> (1) Timing of the moving knife motion is wrong. (2) The button clamp assembly rises too much. 	<ul style="list-style-type: none"> ○ Adjust the position of the moving knife. ○ Reduce the button clamp life down to 9 mm (23/64")

(Please do not hesitate to contact our distributors or agents in your area for further informations when necessary.)



TOKYO JUKI INDUSTRIAL CO., LTD.

Head Office & Plant: 2-1, 8-chome, Kokuryo-cho, Chofu-shi, Tokyo, Japan
 Business Office: 23-3, Kabuki-cho 1-chome, Shinjuku-ku, Tokyo 160, Japan
 Cable: JUKI TOKYO Telex: J22967, 232-2301
 Phone: 03(205)1188, 1189, 1190

Appear and specification listed in this instruction book are subjected to change without notice.

1986. 5 Printed in Japan(T)